

Installation Instructions for the Actuator Interface Terminal Strip

PK 8401 2

DESCRIPTION

The Actuator Interface Terminal Strip (Actuator ITS) provides the interface between the Smart Distributed System and the Programmable Logic Controller (PLC) output modules. The Actuator ITS communicates with up to 16 actuator devices.

The Smart Distributed System can handle up to 126 device addresses (or nodes) and 64 electrical loads. An ITS controls only 16 devices (See the Group ID - Device Number Table below) so there can be up to eight ITSs on a system.

ORDER GUIDE

Catalog Listing	Description
SDS-C1ITS-A16	Actuator Interface Terminal Strip (ITS), 16 current sinking inputs

IDENTIFICATION

The Actuator Interface Terminal Strips must be identified with a letter (A through H) when installed. The letter represents the individual ITS's group ID. Group IDs are selected using on-board DIP switches SW3, SW4 and SW5. ITS "A" will communicate with actuator addresses 1 through 16. Communications for other actuator address locations will be ignored by ITS "A" and received by the ITS with the correct ID location.

GROUP ID-DEVICE NUMBER TABLE

ID	Node	SW3	SW4	SW5
A	1-16	off	off	off
B	17-32	off	off	on
C	33-48	off	on	off
D	49-64	off	on	on
E	65-80	on	off	off
F	81-96	on	off	on
G	97-112	on	on	off
H	113-126	on	on	on

NOTICE

ITS "H" can interface only 14 device addresses. Addresses 127 and 128 are not available.

DIP SWITCHES

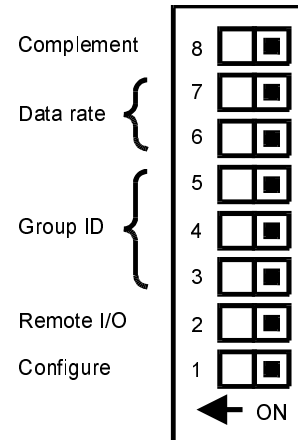

DIP SWITCH ASSIGNMENTS

The DIP switches are used to select the operating parameters, ITS group address, and bus data rate. The DIP switches are located in the lower left corner of the ITS under the access cover. Open the access cover using a small flat-head screwdriver.

NOTICE

Power to the ITS MUST be turned off when changing DIP switch settings.

Switch 1: Configure/Run Mode

Each ITS maintains a list (or map) of the active devices assigned to it in non-volatile memory. When SW1 is on, the ITS will configure the list of active devices in memory every time power is applied. When the SW1 is turned off, the ITS will confirm that all active devices on the previous list are present and operating correctly every time the system is powered-up. If devices cannot be identified, an error signal is initiated in the ITS.

Switch 2: Remote I/O

The Actuator ITS (SDS-C1ITS-A16) can be configured to provide 16 remote inputs. The Actuator ITS Remote Mode Wiring Diagram shows the typical wiring connections. The wiring diagram shows both a mechanical switch and electronic sensor. All 16 input points are wired the same as the two examples.

The Actuator ITS inputs are optically isolated so the input device requires a separate power supply with a voltage range of 11 to 25 VDC. Refer to MICRO SWITCH document 84-08444-1 for additional application information.

ACTUATOR ITS REMOTE MODE WIRING DIAGRAM

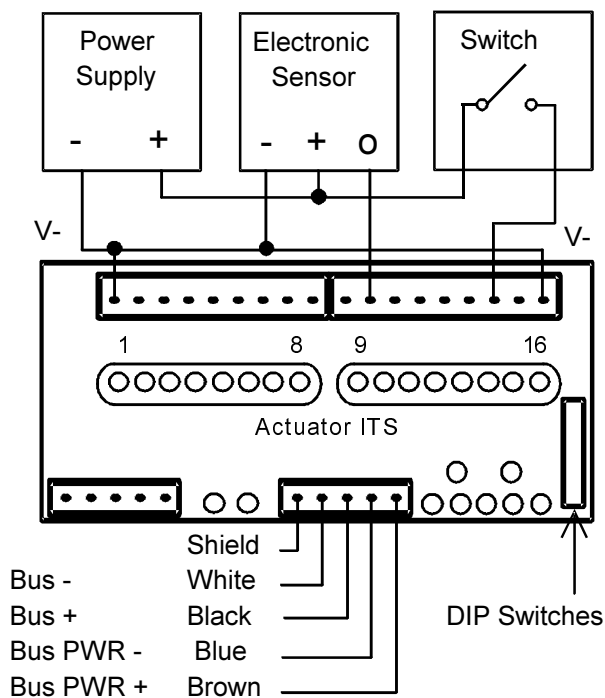

Switches 3 - 5: Group Addresses

An ITS can interface up to 16 devices. There can be eight ITSs on a single bus. Each ITS must be assigned a unique ID letter "A" thru "H," selected via SW3, SW4 and SW5. Each group ID has 16 device addresses assigned to it (See the Group ID - DEVICE NUMBER TABLE for number assignments).

NOTICE

One ITS on every System must be ID "A." If only one ITS is used, it must be configured as "A."

Switches 6 - 7: Data Rate Selection

The data rate for the entire system is established by the ITS with the "A" ID. All other ITSs and sensor or actuator devices automatically sense the data rate and adjust themselves accordingly. The data rate on the "A" ITS (SW3, SW4, and SW5 turned off) is selected via DIP switches SW6 and SW7. See the Data Rate Table for data rates and switch settings.

DATA RATE TABLE

Data Rates	SW6	SW7
125 Kbps	off	off
250 Kbps	off	on
500 Kbps	on	off
1 Mbps	on	on

Switch 8: Complement Mode

When SW8 is turned on, the complement mode performs a binary complement of all ITS I/O points (Normally Open outputs become Normally Closed).

PLUGGABLE TERMINAL BLOCKS

All connections on the ITS are made via pluggable terminal blocks. These terminal blocks have oversized wire clamps to insure a secure connection, while allowing a range of wire sizes from 22 to 10 AWG. The captive clamping screws can be tightened with a small screwdriver.

AUXILIARY

The AUX IN connection may be used to help locate which device on the bus is reporting an error condition. When the ITS receives an AUX IN signal, it lights the NODE LED and displays the device address in the LED array. Refer to the SDS Design

Actuator Interface Terminal Strip

PK 8401 2

and Implementation Guide (Document number 84-08422) for details.

ACTUATOR INTERFACE TERMINAL STRIP SPECIFICATIONS

Electrical	Voltage range	11 to 25 VDC		
	Current consumption	125 mA at 24 VDC		
	Data rates	1 Mbps, 500 Kbps, 250 Kbps, 125 Kbps		
	Response time*	1 Mbps	0.75 mS	
		500 Kbps	1.0 mS	
		250 Kbps	1.25 mS	
		125 Kbps	1.5 mS	
	Operations per Sec.	1 Mbps	800 Typical	
		500 Kbps	500 Typical	
		250 Kbps	300 Typical	
125 Kbps		200 Typical		
Input and Outputs	Actuator Outputs	Type	Current sinking output	
		Number	16	
		Voltage range	11 to 25 VDC	
		Input current	10 mA maximum at 25 VDC	
		Leakage current	100 µA maximum	
		Voltage drop	1.0 VDC maximum	
		Isolation from bus	1500 VAC, Optically Isolated	
	Ready Output	Type	Sink or source	
		Number	1	
		Voltage range	11 to 25 VDC	
		Leakage current	100 µA maximum	
		Voltage drop	0.4VDC maximum	
		Load current	4 mA maximum	
	Aux. Input	Type	Active High	
			Number	1
			Voltage range	11 to 25 VDC
			Input current	10 mA maximum at 25 VDC
Isolation from bus			1500 VAC, Optically Isolated	
Environmental	Temperature	Operating	0 to +60°C (32 to +140°F)	
		Storage	-30 to +70°C (-122 to +158°F)	
	Humidity	95% RH, non-condensing		
	Shock	10 G		
	Vibration	2 G at 10 to 500 Hz		
	Sealing	NEMA 1 (Normal Mounting Means)		
	Standards	FCC	Part 15, Class A	
		UL/CSA	Class 2	
	Physical	Case size	159,3 x 82,6 x 56,6 mm (6.27 x 3.25 x 2.23 inches)	
		Weight	170 grams (6 Oz.)	
Case materials		Valox, PVC, and Acetal		
Mounting		DIN Rail		
Termination		Pluggable terminal blocks		

* Response time for ITS includes communication time and hardware through-put time.

WIRING DIAGRAMS

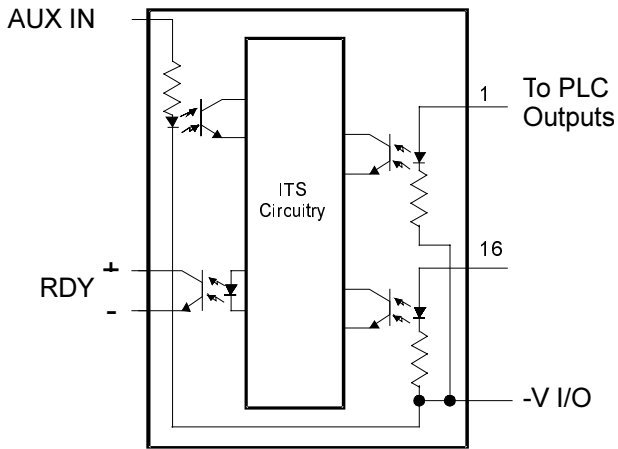

Discrete PLC Connections

Connect the discrete wires from the PLC DC output modules to the corresponding 18 pin pluggable terminal block on the ITS. Also, connect the common of the DC power supply to one or both of the -V I/O pins, 1 and 18. The Eurostyle terminal blocks have screw terminals. A small flat-head screwdriver can be used to connect discrete wires.

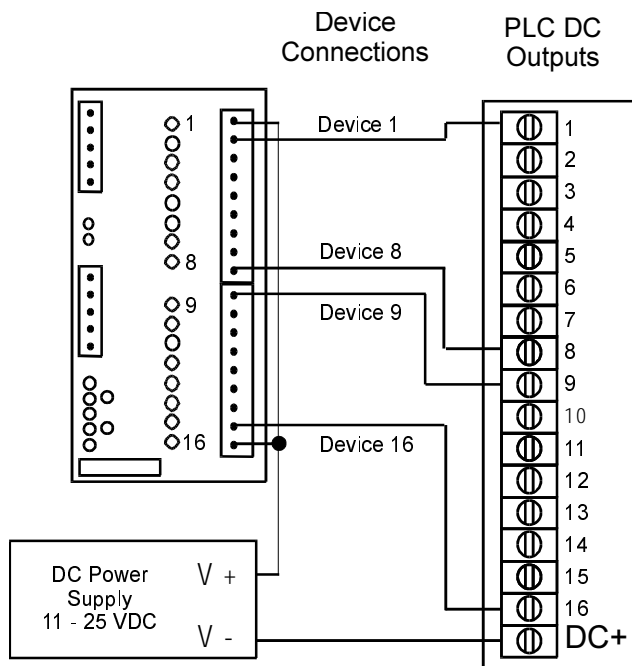

Equivalent Circuit PLC Sinking

When the RDY output is connected to the PLC sinking input, a normal condition is indicated to the PLC by 0 VDC. A fault is indicated by a positive voltage.

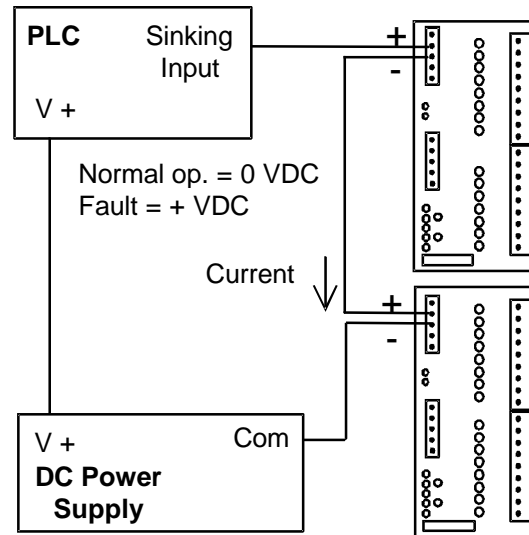

PLC Sourcing

When the RDY output is connected to the PLC sourcing input, a normal condition is indicated to the PLC by a positive voltage. A fault is indicated by 0 VDC.

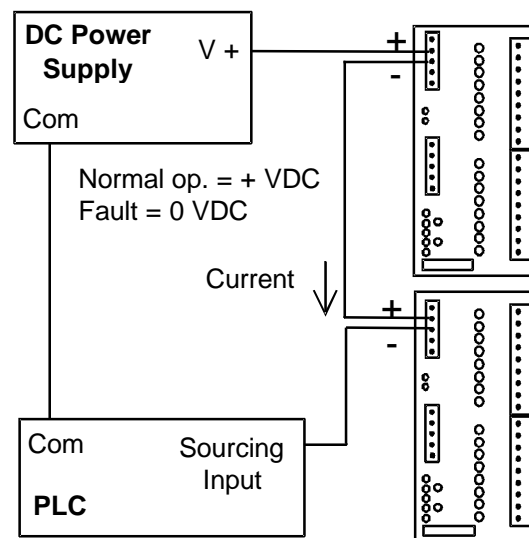

Actuator Interface Terminal Strip

PK 8401 2

ITS Bus and Power Connections

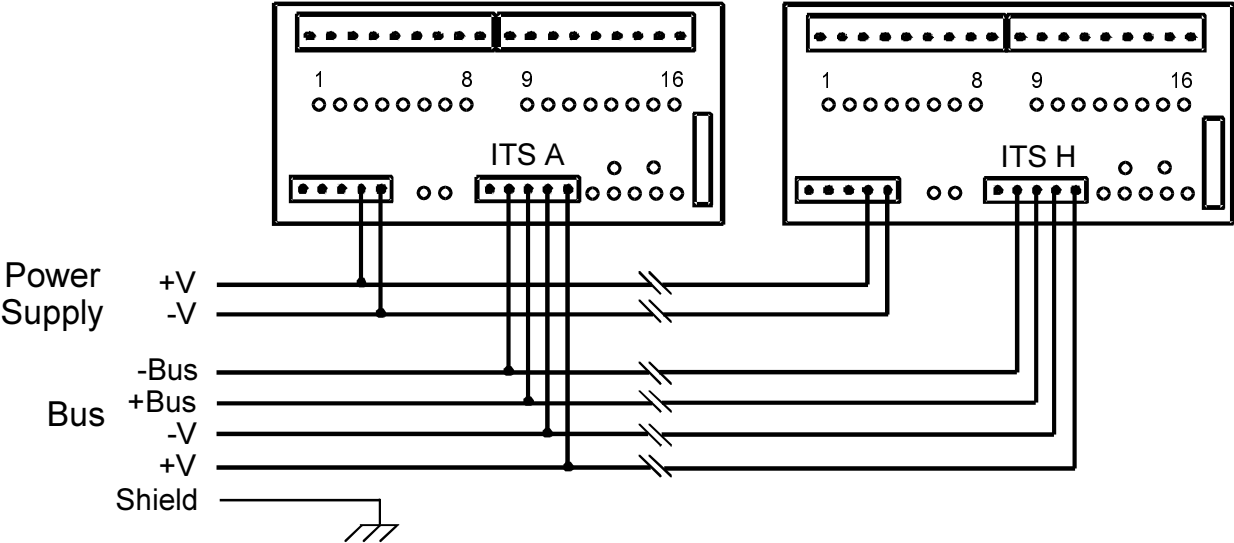

MAIN TRUNK CABLE CONNECTION

ITS Bus Terminal Connections	Wire Color	Mini Pin #
Bus Shield	Shielding	1
Bus Power (+)	Brown	2
Bus Power (-)	Blue	3
+ Bus	Black	4
- Bus	White	5

TERMINATION RESISTOR

The System bus must be configured with a single trunk. There must be only two termination resistors located at the extreme ends of the main trunk, connected between the + BUS and - BUS conductors. The termination resistors should be 120 Ohms, 1/2 Watt, 2% resistors.

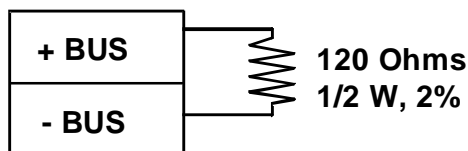

ERROR LEDS

When the ERROR LED is on, the error code LEDs (1, 2, 4, 8, 16) indicate error codes as shown in the ERROR CODE TABLE. When the NODE LED is on, the error code LEDs indicate the device address with the error. If the problem is in a device, the error code LEDs will indicate an error in a device when the ERROR LED is on and the device address when the Node LED is on.

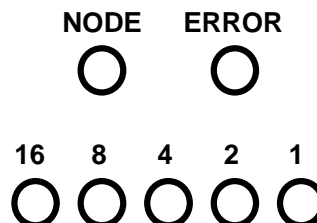

ERROR CODE TABLE

LED	ERROR	REMEDY
1	Checksum error	Actuator device should be replaced
2	Reserved	
4	Device off bus error	Check bus wiring for disconnections or breaks
8	Device error	Check operation of sensor device indicated by LED
16	Missing device error	Check operation of sensor device indicated by LED

DEVICE ADDRESS TABLE

ITS LEDs: ● = on, ○ = off					Device Address, ITS IDs							
16	8	4	2	1	ID A	ID B	ID C	ID D	ID E	ID F	ID G	ID H
○	○	○	○	○	NO*	NO*	NO*	NO*	NO*	NO*	NO*	NO*
○	○	○	○	●	1	17	33	49	65	81	97	113
○	○	○	●	○	2	18	34	50	66	82	98	114
○	○	○	●	●	3	19	35	51	67	83	99	115
○	○	●	○	○	4	20	36	52	68	84	100	116
○	○	●	○	●	5	21	37	53	69	85	101	117
○	○	●	●	○	6	22	38	54	70	86	102	118
○	○	●	●	●	7	23	39	55	71	87	103	119
○	●	○	○	○	8	24	40	56	72	88	104	120
○	●	○	○	●	9	25	41	57	73	89	105	121
○	●	○	●	○	10	26	42	58	74	90	106	122
○	●	○	●	●	11	27	43	59	75	91	107	123
○	●	●	○	○	12	28	44	60	76	92	108	124
○	●	●	○	●	13	29	45	61	77	93	109	125
○	●	●	●	○	14	30	46	62	78	94	110	126
○	●	●	●	●	15	31	47	63	79	95	111	NA**
●	○	○	○	○	16	32	48	64	80	96	112	NA**

*NO = Normal Operation **NA = Not Available

Actuator Interface Terminal Strip

PK 8401 2

ITS READY OUTPUT CONNECTIONS

Use the Ready Output (RDY) connections to provide indication of an error or fault condition to the control system in one or more of the ITSs. When the ITS detects no faults, RDY terminals act like a closed switch. When the ITS detects an error condition, the RDY terminals act like an open switch.

MOUNTING DIMENSIONS (for reference only)

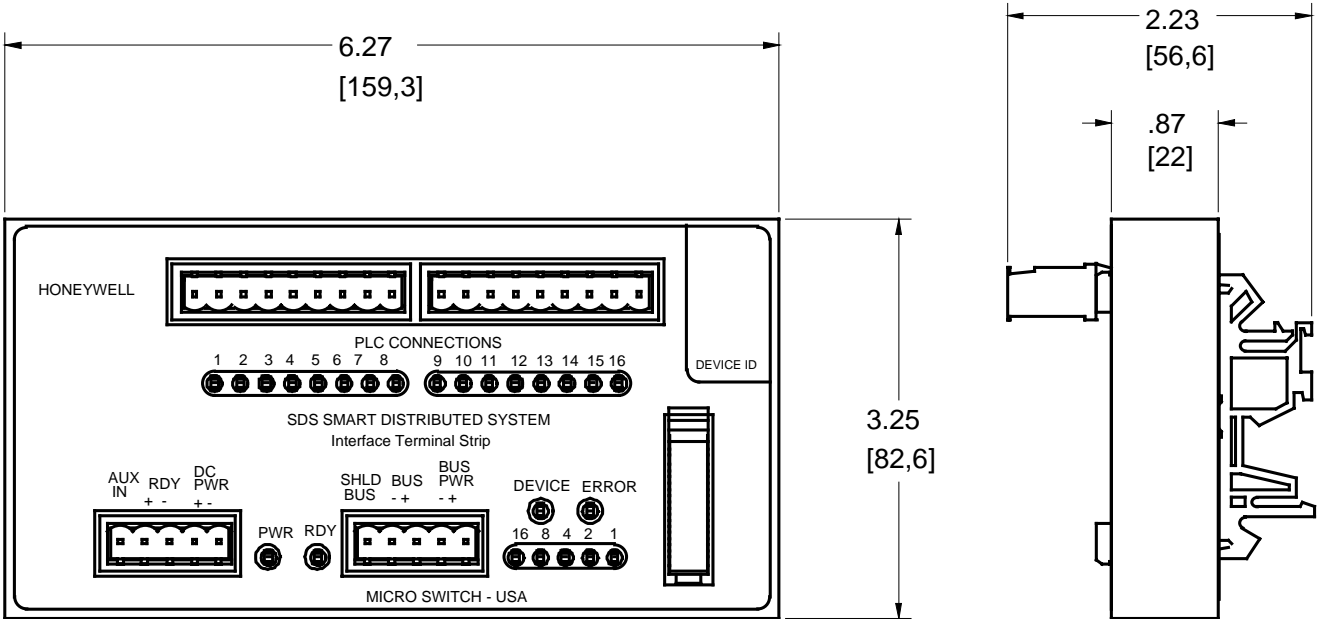

SALES AND SERVICE

Honeywell's MICRO SWITCH Division serves its customers through a worldwide network of sales offices and distributors. For application assistance, current specifications, pricing or name of the nearest Authorized Distributor, contact a nearby sales office. Or call:

1-800-537-6945, USA

1-800-737-3360, Canada

1-815-235-6847, International

Internet E-mail Address:

sds@p02.il50.micro.honeywell.com

Specifications may change at any time and without notice. The information we supply is believed to be accurate and reliable as of this printing. However, we assume no responsibility for its use.

While we provide application assistance, personally and through our literature, it is up to the customer to determine the suitability of the product in the application.

WARRANTY/REMEDY

Honeywell warrants goods of its manufacture as being free of defective materials and faulty workmanship. Commencing with date of shipment, Honeywell's warranty runs for 18 months. If warranted goods are returned to Honeywell during that period of coverage, Honeywell will repair or replace without charge those items it finds defective. The foregoing is Buyer's sole remedy and is **in lieu of all other warranties, expressed or implied, including those of merchantability and fitness for particular purpose.**